

# Product Specification

## Senseair<sup>®</sup> LP8

Miniature CO<sub>2</sub> sensor module  
for battery-powered applications



### General

Senseair LP8 is a miniature sensor module for battery-powered applications. It gives a full control on sensor integration into a host system, flexibility in changing of the CO<sub>2</sub> measurement, period and power consumption. One measurement requires 3.6mC of charge (or energy 11.9mJ at 3.3V battery supply). To minimise power consumption, the sensor should be turned OFF between measurements.

<b>Item</b>	Senseair LP8 Article No. 005-0-0001, 005-0-0003	
<b>Target gas</b>	Carbon dioxide (CO <sub>2</sub> )	
<b>Operating Principle</b>	Non-dispersive infrared (NDIR)	
<b>Operating environment range</b>	0 – 50°C, 0 – 85%RH (non-condensing)	
<b>Measurement range, calibrated</b>	0 – 2000ppm (extended range up to 10000ppm)	
<b>Accuracy CO<sub>2</sub></b>	±50ppm, ±3% of reading <sup>1,2,3</sup> (extended range ±10% of reading) <sup>1,2,3,4</sup>	
<b>RMS noise CO<sub>2</sub></b>	14ppm @ 400ppm, 25°C, 25ppm @ 1000ppm, 25°C	
<b>Accuracy Temperature</b>	±0.7°C	
<b>Storage Temperature</b>	-40 – 70°C	
<b>Power supply</b>	2.9 – 5.5V unprotected against surges and reverse connection	
<b>Peak current max</b>	140mA @ 0°C (typical 125mA @ 25°C)	
<b>Leakage Shutdown current</b>	1µA <sup>5,6</sup>	
<b>Charge per measurement</b>	3.6mC (3.9mC worst case)	
<b>Energy per measurement</b>	11.9mJ @ 3.3V (measurement period 16s)	
<b>Current consumption</b> 16second sampling 60second sampling	245µA <sup>5,6</sup> 66µA <sup>5,6</sup> (3.2mJ)	
<b>Measurement period</b>	≥16s	
<b>Measurement repeatability</b>	Max. ±1% of specified CO <sub>2</sub> concentration, ±10ppm @ 1000ppm	
<b>Response time T<sub>90%</sub></b> 16 seconds sampling 60 seconds sampling	Non-filtered signal 4 minutes 3 minutes	Filtered signal 7 minutes 10 minutes
<b>Dimensions</b> 005-0-0001 (with pin headers) 005-0-0003 (no pin headers)	33.4 x 19.9 x 12.4mm (max dimensions L x W x H) 33.4 x 19.9 x 8.5mm	
<b>Life expectancy</b>	>15 years	
<b>Storage temperature</b>	-40 – 70°C	
<b>Weight</b>	<8g	
<b>Serial communication</b>	UART (host-slave protocol)	
<b>Maintenance</b>	A host system counts ABC (Automatic Baseline Correction) period itself and has to write ABC command to the Calculation Control byte when ABC period (eight (8) days) expires.	

Table 1. Key technical specification for the Senseair LP8

- Note 1: Accuracy is met at 10 – 40°C, 0 – 60%RH, after minimum three (3) performed Automatic Baseline Corrections, preferably spanning eight (8) days in-between, or a successful zero-calibration.
- Note 2: Based on reading filtered CO<sub>2</sub> measurement data in stable environments and in continuous operation by control mode
- Note 3: Accuracy specification is referred to calibration gas mixtures with additional uncertainty of ±1%
- Note 4: Extended range accuracy is not calibrated or guaranteed, it is extrapolated from calibrated range
- Note 5: Resistor network for measuring VCAP voltage adds 14µA @ 5.5V
- Note 6: External super-capacitor leakage is not considered

## Installation and soldering

See Senseair LP8 Handling manual (ANO1332).

## Sample gas diffusion area

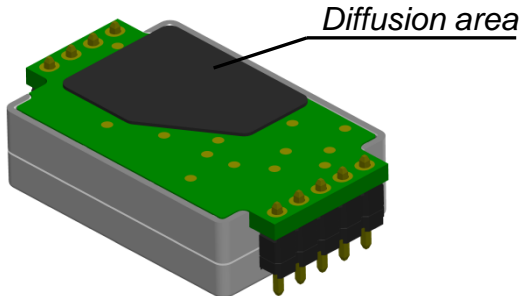

Figure 1. Diffusion area

## Mechanical properties

See Senseair LP8 Handling manual (ANO1332).

## Pin assignment

Bottom layer

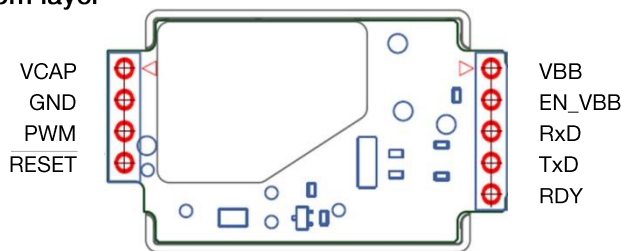

Figure 2. Pin assignment

Pin #	Name	Type	Maximum Voltage, V	Description
<b>JP1 (4-pin header)</b>				
1	VCAP	Power	6.5	Lamp driver supply voltage
2	GND	Power	-	Ground
3	PWM	Output	2.5	I/O pin. PWM output or other function can be assigned.
4	RESET	Input	2.5	Reset. Pull-up resistor (10k) is connected to 2.5V
<b>JP2 (5-pin header)</b>				
1	VBB	Power	5.5	Supply voltage
2	EN_VBB	Input	VBB	Enable pin to activate voltage regulator. $I_{Max} = 2\mu A$ , in logic low state.
3	RxD	Input	3.6	UART receive pin to sensor MCU from host
4	TxD	Output	2.5	UART transmit pin from sensor MCU to host
5	RDY	Output	2.5	Signal is used to synchronise sensor with a host system.

Table 2. Terminals and I/O options dedicated in Senseair LP8 model

# Time diagram

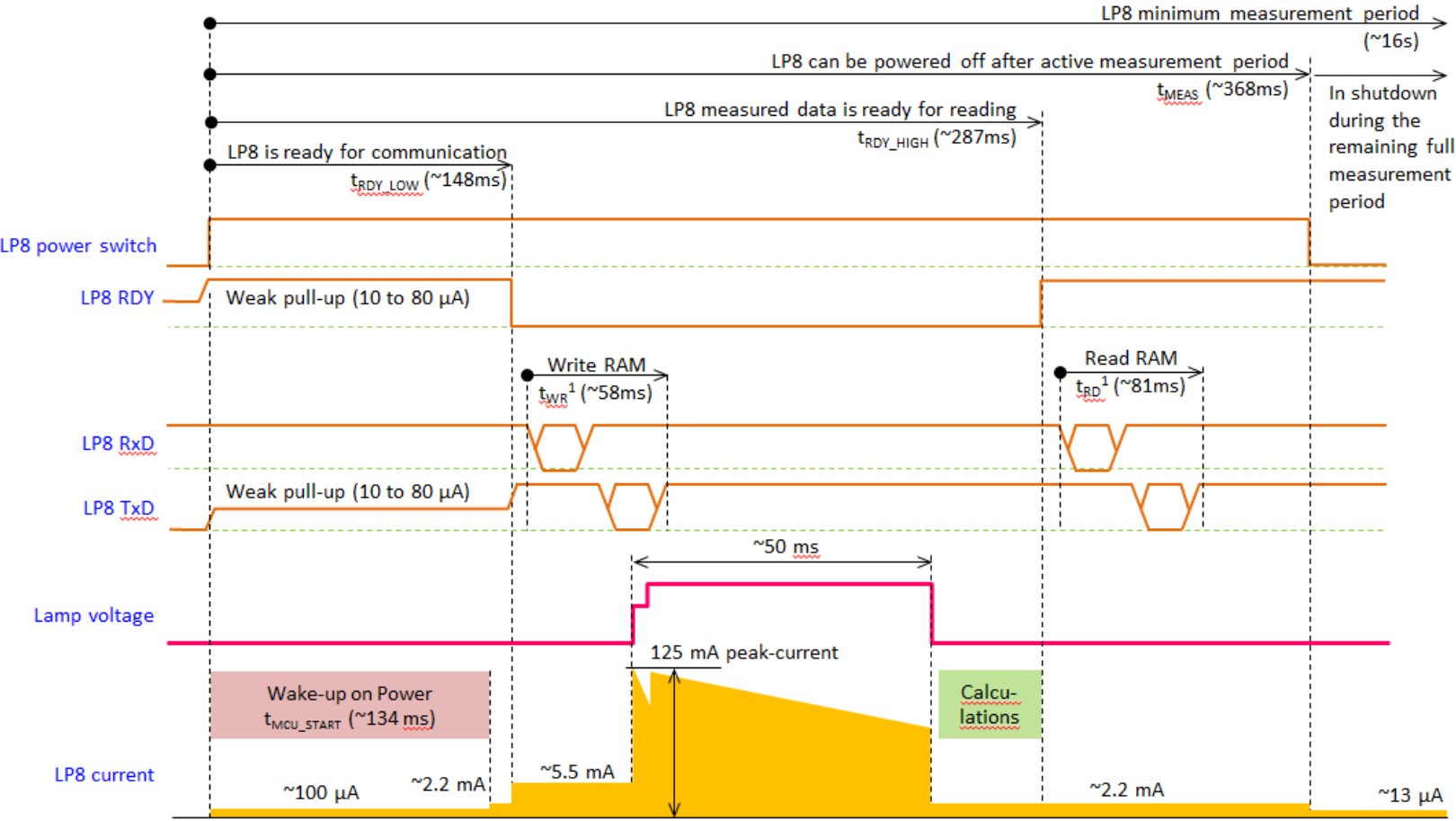

Figure 3. Time diagram

Note 1: typical values for 9600 baud rate



## Self-diagnostics

All EEPROM updates are checked by subsequent memory read back and data comparisons. EEPROM consistency is checked by page checksum calculation.

## Electrical specification

Parameter	Min	Typical	Max	Unit	Test conditions
Power supply voltage: VBB (electronics) VCAP (lamp)	2.9 2.9		5.5 6.5	V V	
Peak current: VBB (electronics) <sup>1</sup> VCAP (lamp) <sup>2</sup> VCAP (lamp) <sup>2</sup>		5.4 119	6 129 134	mA mA mA	VBB = VCAP = 2.9 – 5.5V T <sub>amb</sub> = 0 – 50°C T <sub>amb</sub> = 25°C T <sub>amb</sub> = 0°C <sup>3</sup>
Total (VBB + VCAP)		125	140	mA	T <sub>amb</sub> = 0 – 50°C
Leakage shutdown current VBB (electronics) <sup>4</sup> VCAP (lamp) 500kΩ resistor network VCAP (lamp) without voltage monitoring <sup>5</sup>		1 12 0.1	2 14 0.2	μA μA μA	T <sub>amb</sub> = 25°C T <sub>amb</sub> = 25°C, VCAP = 5.5V T <sub>amb</sub> = 25°C, VCAP = 5.5V
Charge per measurement cycle  VBB (electronics)  VCAP (lamp)		1.1 1.0 2.5	1.2 1.1 2.7	mC mC mC	T <sub>amb</sub> = 0 – 50°C, VBB = VCAP = 2.9 – 5.5V Baudrate: 9600 Baudrate: 19200

Table 3. Electrical specification

Note 1: Charging of 20μF decoupling capacitance is not considered

Note 2: Charging of 220nF decoupling capacitance is not considered

Note 3: Peak-current decreases with increasing temperatures

Note 4: Without pull-down resistor 100k on EN\_VBB (as default, this is not mounted on Senseair LP8)

Note 5: Currently not available as purchasable option

## Recommended host connection

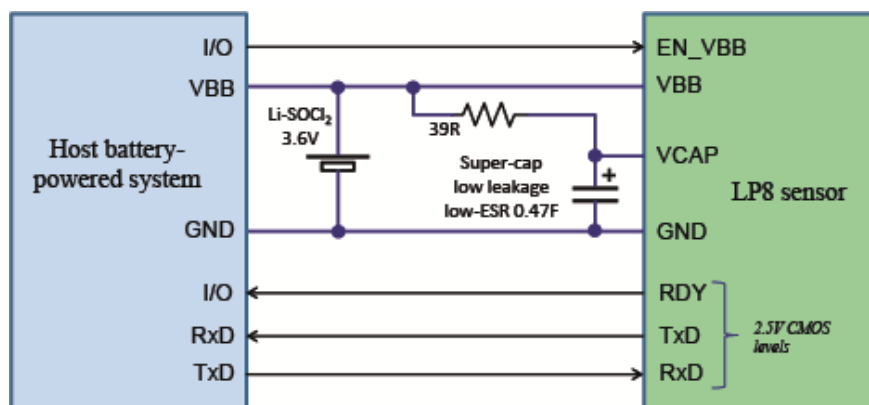

Figure 4. Recommended host connection

- In some battery-powered systems, current limiter can be a simply 5Ω resistor.
- Suggested super-capacitor type is Eaton Bussman PM-5R0H474-R (0.47F 5V). It is specified for 8μA leakage current @ 5V, 20°C and 500mΩ ESR.
- An external low-leakage switch (for example TPS22907) can be used to switch OFF both VCAP and VBB between measurements. VBB can be supplied from super-capacitor.

## Sensor control by a host MCU system

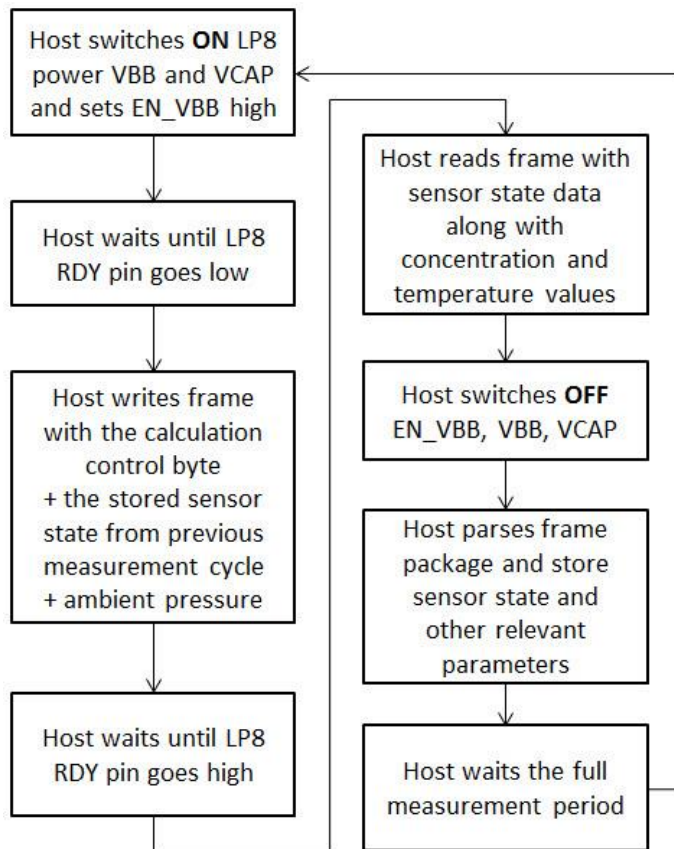

Figure 5. Sensor control by a host MCU system

Measurement period of the sensor is determined by customer host system and may vary without degrading measurement accuracy. Minimum allowed measurement period is 16 seconds (below 16 seconds, accuracy is not guaranteed).

## Calibration

### ABC:

A host system counts ABC period itself and has to write ABC command to the “Calculation Control byte” when ABC period (eight days) expires. The lowest CO<sub>2</sub> value (400ppm defines in this case as fresh air, included “remembered accompanying parameters”) measured during the period from the last “Initial state”- / “ABC”- / “Background”- / “Zero calibration” writes to the “Calculation Control” byte.

### Background calibration:

- Using unfiltered channel, sensor considers current unfiltered measurement values to provide calibration.
- Using filtered channel, sensor considers filtered values to provide calibration (sensor has to be exposed for fresh air >40 lamp pulses/measurement periods).

### Zero calibration:

- Using unfiltered channel, sensor considers current unfiltered measurement values to provide calibration.
- Using filtered channel, sensor considers filtered values to provide calibration (sensor has to be exposed for zero gas >40 lamp pulses).

The LP8 sensor works as a slave and totally acts on the host/master actions applied through the “Calculation Control” byte.

Default position: slave- power OFF (requires sensor power OFF).

Sensor power ON: the sensor can perform the next measurement.

## Error code and action plan

### ErrorStatus0 byte description

Bit	Bit Name	Error Description	Suggested Action
0	Fatal Error	<b>Fatal Error</b> The bit is a joint bit for different error sources when sensor cannot provide correct operation, among them: <ul style="list-style-type: none"> <li>• Configuration EEPROM parameters are out of range or corrupted</li> <li>• Virtual EEPROM memory read/write error</li> <li>• Error in VCAP measurements</li> </ul>	Switch OFF/ON sensor power and start with “Initial Measurement” in the Calculation Control byte. Contact local distributor.
2	AlgError	<b>Algorithm Error</b> Configuration EEPROM parameters are out of range or corrupted	
3	Calibration	<b>Calibration Calculation Error</b> Out of range error at Zero-/Background calibration and ABC	Repeat recalibration or wait until next ABC event.
4	SelfDiag	<b>Self-Diagnostics Error</b> Hardware error is detected or important EEPROM parameters are corrupted	Contact local distributor.
5	OutOfRange	<b>Out Of Range Error (OOR)</b> Indicates an error which occurs at different stages of concentration calculation algorithm. Resets automatically after source of error disappears.	Try sensor in fresh air. Perform sensor zero or background calibration. Check sensor temperature readings.
6	Memory	<b>Memory Error</b> Virtual EEPROM read/write error: page checksum error during read or write verification, FLASH operation error.	Contact local distributor.
7	WarmUp	<b>WarmUp bit</b> Bit is not set in customer mode	-

Table 4. ErrorStatus0 byte description

### ErrorStatus1 byte description

Bit	Bit Name	Error Description	Suggested Action
0	VCAP1 low	<b>VCAP1 voltage low</b> Voltage measured prior lamp pulse is below preset threshold. The threshold is 2.8V $\pm$ 3%.	Check battery. Sensor supply voltage is below specified operational limit of 2.9V.
1	VCAP2 low	<b>VCAP2 voltage low</b> Average voltage measured at the beginning of lamp pulse (during inrush steps) is below preset threshold 2.7V $\pm$ 3%.	ESR (Equivalent series resistance) of the sensor power supply source (a battery or super-capacitor) is not enough to provide low-voltage drop during 140mA lamp inrush step.
2	ADC Error	<b>ADC Error</b> MCU ADC out-of-range error has occurred.	Switch OFF/ON sensor power and apply “initial measurement” to the Calculation Control byte. Contact local distributor.
3	Reserved		
4-7	Parameters override bits	These bits indicate which parameter is forced to a predefined value in the debug mode. Should not appear during normal operation.	-

Table 5 ErrorStatus1 byte description

Bits 3 – 0 of the **ErrorStatus2-** and **ErrorStatus3** bytes decode on what algorithm stage an “Out Of Range Error” (OOR) has occurred in unfiltered- and filtered calculation channel respectively.

## Maintenance

Senseair LP8 has a built-in self-correcting ABC algorithm. ABC period is adjustable by host. Discuss your application with Senseair in order to get advice for a proper calibration strategy.

[www.senseair.com](http://www.senseair.com)